

TA1K & TA2K

High Wattage Heat Sinkable Planar Resistor

The TAP series delivers 1000W or 2000W of continuous power when properly mounted to a liquid cooled heat sink (based on 85°C mounting plate temperature)

Applications include power conditioning, power distribution, power conversion, and power control.



FEATURES

- High Energy Rating
- Low Inductance
- Resistor Element Electrically Isolated
- High Dielectric Strength
- Small Footprint

APPLICATIONS

- Power semiconductor balancing
- Motor control
- Inrush Current Limiting

CHARACTERISTICS

Resistor Element	Thick Film on Alumina Substrate
Power Rating	1000W or 2000W at 85°C mounting plate
Resistance Values	0.5Ω to 1000Ω
Resistance Tolerance	+10% std.
Max Operating Voltage	2000VDC
Temperature Coefficient	± 250 PPM/°C
Dielectric Strength	6KV standard
Operating Temperature Range	-55°C to 85°C
Terminal Screws	#10-32
Max Contacts Torque	10 in-lb
Mounting Screws	#8-32
Max Mounting Torque	15 in-lb
Creepage Distance	50mm ± 1mm (min)

Test	Rating	
	Continuous	Pulse
Rated Power, max. current and heat sink plate temperature limited	(TA1K0) 1000W (TA2K0) 2000W	
Operating Voltage	$\sqrt{P \cdot R}$	N/A
Max. Applied Voltage, ohms law limited	223V	2000VDC
Max. Current	10A	53.33A
Critical Resistance; below this resistance max power has to be de-rated due to exceeding max current	(TA1K0) 10Ω (TA2K0) 20Ω	

Test	Method	Maximum ΔR
Short Time Overload	$1.14 \times \sqrt{P \cdot R} / 10 \text{ sec @ } 70^\circ\text{C}$	Max % ΔRsto = ±(2% + 0.05Ω)
Moisture Resistance	(TA1K0) 1000 hrs @ 40°C, 90-95% RH (TA2K0) 1750 hrs @ 40°C, 90-95% RH	≤1%
Thermal Shock	MIL-STD-202, Method 107	MIL-STD-202, Method 107
Vibration, elec.	MIL-STD-202, Method 201	±2% Resistance
Vibration, mech.	MIL-STD-202, Method 201	No Loose Terminal Screws
Load Life	(TA1K0) 1000 Hrs 90 min ON / 30 min OFF (TA2K0) 1750 Hrs 90 min ON / 30 min OFF	≤1%
Pulse Tolerance	52μF @ 2KV / 60 sec intervals, 104J, 20,000 Pulses	≤1%
Dielectric Strength	6KVDC for 1 minute	≤1%

Derating

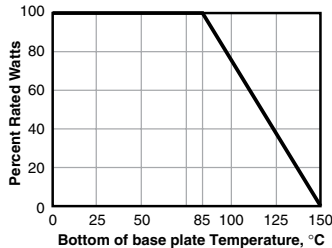

(continued)

TA1K & TA2K

High Wattage Heat Sinkable Planar Resistor

DIMENSIONS

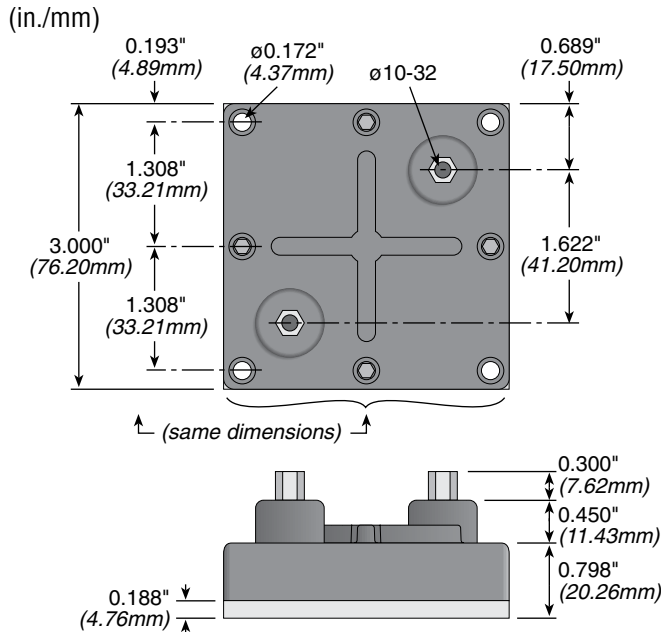

APPLICATION NOTES

Proper heat sinking techniques are essential to performance of a TAP resistor. Please follow these guidelines when designing TAP system:

- Heatsink plate (base plate of the resistor) temperature must be monitored to establish proper de-rating. Best technique is to attach a thermocouple to the side of the base plate of the resistor. Temperature of plastic housing or heat sink cannot be used to establish rating of the resistor. Usage of laser thermometers should be avoided.
- To obtain a power rating of 1000W or 2000W, the bottom case temp must not exceed 85°C. This can only be achieved if the thermal conduction to the heatsink $R_{th-cs} < 0.025^\circ\text{K/W}$. This value can be reached by using thermal transfer compound with a heat conductivity of 1W/mK. The flatness of the cooling plate must be better than 0.05mm overall. The roughness of the surface should not exceed 6.4µm.
- Due to very high power density, only liquid cooled heat sinks are recommended for applications when >300W power rating is desired.
- Properly designed heat sink should have more than 2 cooling pipes under the surface of the TAP resistor. The Ohmite CP4 heat sink (<https://www.ohmite.com/cp4-series-chillplate/>) is an example of properly designed heat sink.

ORDERING INFORMATION

RoHS Compliant

TA1K0PH2R50KE

Style	Wattage	Package Type	Resistance	Tolerance
1	2.5	PH2R	50	K
			2.5Ω = 2R50	K = 10% (standard)
			50Ω = 50R0	L = 20%

Standard Part Numbers

Ohms	1000 Watt 10% Tolerance		Ohms	2000 Watt 10% Tolerance	
	Part Number	Part Number			
0.5	TA1K0PHR500KE	TA2K0PHR500KE	0.5	TA2K0PH1R00KE	TA2K0PH1R00KE
1	TA1K0PH1R00KE	TA2K0PH2R50KE	2.5	TA2K0PH5R00KE	TA2K0PH7R50KE
2.5	TA1K0PH2R50KE	TA2K0PH10R0KE	10	TA2K0PH15R0KE	TA2K0PH25R0KE
5	TA1K0PH5R00KE	TA2K0PH25R0KE	25	TA2K0PH50R0KE	TA2K0PH100RKE
7.5	TA1K0PH7R50KE	TA2K0PH50R0KE	50	TA2K0PH250RKE	TA2K0PH500RKE
10	TA1K0PH10R0KE	TA2K0PH750RKE	750	TA2K0PH750RKE	TA2K0PH1K00KE
15	TA1K0PH15R0KE		1000		
25	TA1K0PH25R0KE				
50	TA1K0PH50R0KE				
100	TA1K0PH100RKE				
250	TA1K0PH250RKE				
500	TA1K0PH500RKE				
750	TA1K0PH750RKE				
1000	TA1K0PH1K00KE				